



Installation Instructions

For ViWinTech New Construction Windows

ViWinTech recommends using Installation masters™ Certified Installer or an experienced professional contractor who practices Installation Masters methods to provide the proper operation and weather tight seal to the building. These installation instructions are general guidelines for standard wood construction; other methods can be used at the discretion of the architect or professional installer to provide the best weather tight installation. ViWinTech is NOT responsible for the quality of the installation.

Failure to adequately install and properly maintain the window will void any warranty, written or implied. The installer is responsible for proper installation guidelines in accordance with any local/state applicable codes and/or ordinances.

WARNING

- Follow manufacturers' instructions for hand and power tools. Always wear safety glasses. Failure to do so could result in injury, product or property damage.
- Windows can be heavy. Use safe lifting techniques and a reasonable number of people with enough strength to lift, carry and install window products. Heavier windows will require mechanical assistance. Failure to do so could result in injury, product or property damage.
- Do not lift or carry windows by any applied exterior accessories or extension jambs. Doing so could result in injury, product or property damage.
- Windows and installation components can have sharp edges. Wear protective equipment when handling. Failure to do so could result in injury.
- Use caution when working at elevated heights and around window openings. Follow the manufactures' instructions for ladders and scaffolding. Failure to do so could result in injury or death.
- Support windows in opening at all times until fastened. Failure to do so could result in window falling out causing injury, property or product damage.
- Metal fasteners and components could corrode when exposed to preservative-treated or fire-retardant treated lumber. Use approved fasteners and components to fasten window. Failure to do so could cause a failure resulting in injury, product or property damage.
- Unless specifically ordered, windows are not equipped with safety glass, and if broken, could fragment causing injury. Many laws and building codes require safety glass in certain locations.

 **CAUTION**

- Prior to installation, store windows in a near vertical position, never lay flat. Always protect from outside elements when storing or transporting and never store factory wrapped windows in direct sunlight or in storage containers when excessive heat may build up.
- Because all construction must anticipate some water infiltration, it is important that the wall system be designed and constructed to properly manage moisture. ViWinTech is not responsible for claims or damage caused by anticipated and unanticipated water infiltration; deficiencies in building design, construction and maintenance; failure to install ViWinTech products in accordance with ViWinTech's installation instructions; or the use of ViWinTech's products in wall systems which do not allow for proper management of moisture within the wall system.
- Follow the instructions of foam, sealant, and flashing manufacturer regarding safety, material application, compatibility, and periodic maintenance for continued weather resistance of their products. Failure to do so could result in product or property damage.
- Acid solutions commonly used to wash masonry will damage glass, fasteners, and hardware. Follow cleaning solution manufacturer's recommendations carefully. Protect and/or cover windows during cleaning process to prevent acid contact. If solution does come in contact with unit, immediately wash with clean water.

PRECAUTIONARY INSTALLATION NOTES

- Installation flanges **DO NOT** take the place of window flashing tape or liquid flashing. Window must be properly flashed and sealed with a material compatible sealant for protection against water and air infiltration. Failure to do so could result in product or property damage.
- **DO NOT** set window directly on sill plate. Elevate window with shims under the side jambs. Failure to do so could cause bowing of the sill and affect operation and product performance.
- Window must be properly shimmed. Failure to do so could affect operation and product performance.
- A continuous full perimeter interior seal between window frame and the opening is required. Failure to do so will affect product performance.
- Protect window sills during construction. Failure to do so could result in product damage.
- **DO NOT** apply any type of film to insulated glass. Doing so could cause thermal stress conditions and result in glass damage.
- **DO NOT** drill or screw through the window sill. Doing so could cause water leakage.
- For **BRICK** or **MASONRY** installation leave a minimum of 3/8" clearance around the main frame to allow for expansion. Failure to do so could cause bowing and distortion of the main frame.
- For **TRIM** and **SIDING**, allow 1/4" clearance around main frame to allow for expansion.

PREPARING FOR NEW CONSTRUCTION WINDOW INSTALLATION

YOU WILL NEED TO SUPPLY:

- Moisture Resistant Shims 
- Sealant 
- Fasteners 
- Self-Adhering Flashing Tape 
- House Wrap Tape 

TOOLS REQUIRED:

- Safety Glasses 
- Protective Gloves 
- Tape Measure 
- Level 
- Hammer 
- Utility Knife 
- Drill/Driver 
- Putty Knife 
- Caulking Gun 
- Staple Gun 
- J-Roller 

Other construction materials may be required. Read and understand the instructions before you begin.

INSTALLATION

ROUGH OPENING VERIFICATION

1. Confirm the opening is plumb and level.
2. Confirm the window will fit the opening. Measure all four sides of the opening to make sure it is 1/2" to 3/4" larger than the window in both width and height.
3. Confirm the opening is square. Measure diagonally across the opening, the measurements should be within 1/8".

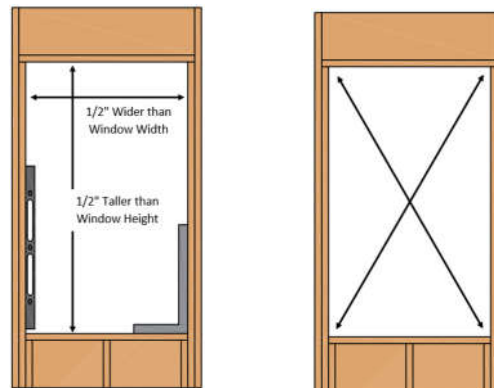

PREPARE THE OPENING

1. Cut the building wrap along the top of the opening.
2. Make a cut from top center down 2/3 of the opening.
3. From bottom of center cut, make a cut to each bottom corner.
4. At top of opening, make a 45-degree cut 6" up and 6" over on each side of the opening.

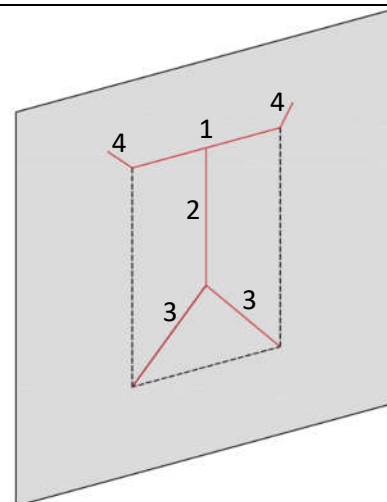

5. Fold the building wrap in at the jambs and staple it in place.
6. Fold bottom of the building wrap in at the sill and staple it in place.
7. Fold the top flap up and temporarily fasten with tape.

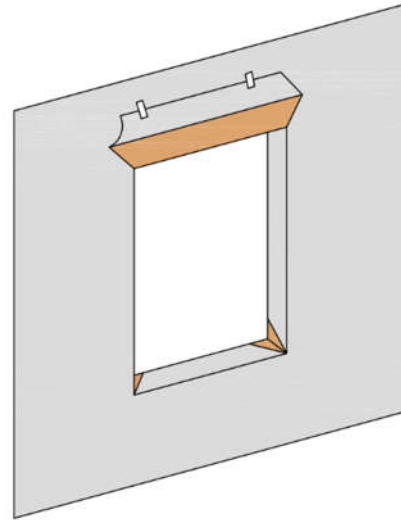

IMPORTANT

Make sure there are no protrusions in the house sheathing that extend past the framing.

8. Cut 2 pieces of Self-Adhering Flashing tape 12" longer than the opening width.
9. Apply the first flashing tape at the sill extending 1" to the exterior and 6" up each side jamb.
10. Cut 1" wide tabs at each corner by cutting the tape 1/2" each way from the corner.
11. Apply the second flashing tape, overlapping the first tape by 1" minimum.
12. Use J-Roller to press the flashing tape down firmly, making sure the corners are 90 degrees.

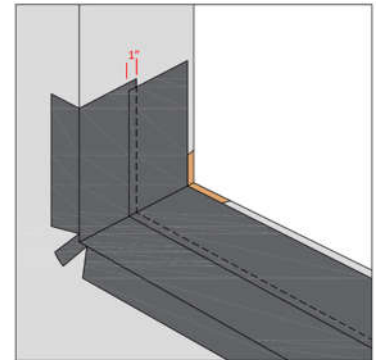
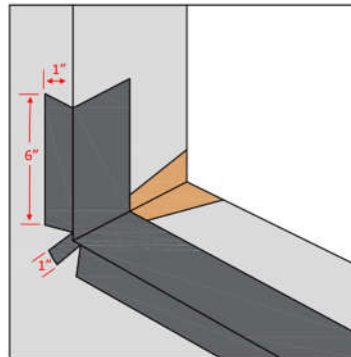

SETTING THE WINDOW

1. Place 1" wide x 1/4" to 3/8" thick shims 1/2" from each side corner.
2. Place additional shims under each twin or triple mullion and sliding window interlock.
3. Make sure shims are level across sill. Attach shims after they are level to prevent movement.

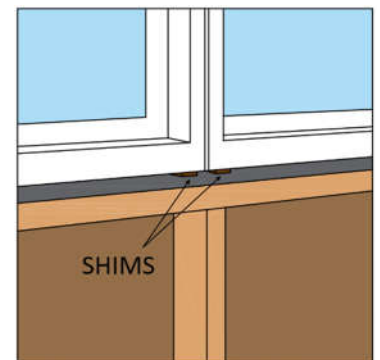
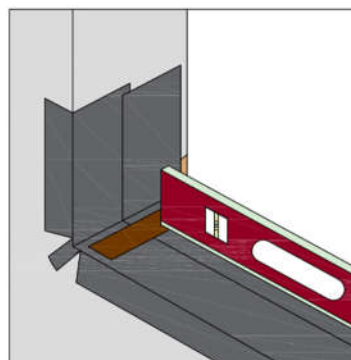

IMPORTANT

***DO NOT** set window directly on sill plate. Elevate window on shims at side jambs. Sill plate may bow window sill and interfere with window operation.*

4. Apply a 3/8" sealant bead at the top and both sides of the opening, no more than 1/2" from the edge of opening.
5. With the sash closed and locked, set the window on shims and center window in the opening.
6. Temporarily fasten with a single fastener at top through the pre-punched hole.

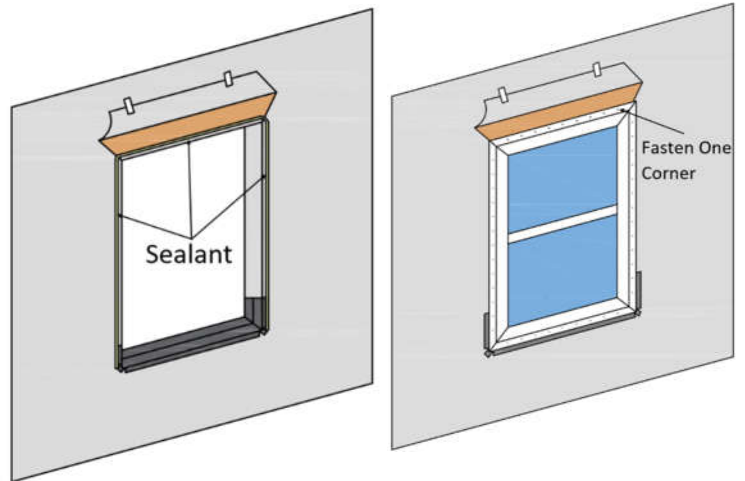

7. Plumb and square the window using shims at the locations shown. Adjust shims to plumb and square the window. For windows over 53" tall, apply shims halfway between center shim and upper and lower shims on both sides. Unlock and open sash slightly and check space between the sash and frame. Adjust shims as needed for equal reveal.
8. Check window operation, then close and lock the window.

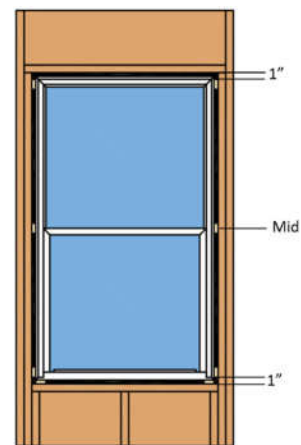

IMPORTANT

Over shimming can cause bowing and prevent proper window operation.

9. Secure window to the opening through every pre-punched hole in all nail fins.

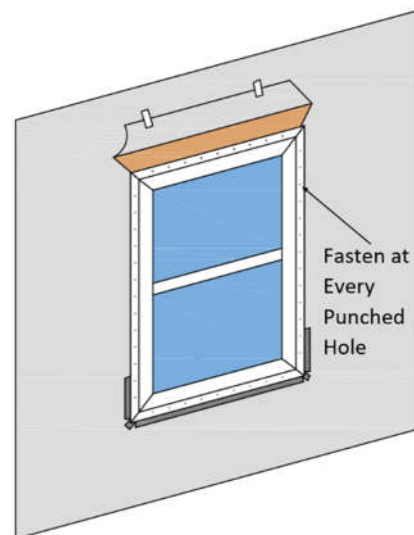

FASTENER CHART

Fastener	Substrate	Min. Head	Min. Shank	Embedment	Spacing
Roofing Nail	Wood	5/16"	11 ga	1"	Every Hole
Wood Screw	Wood	5/16"	#6	1"	Every Hole
Self-Tap Screw	Metal	5/16"	#8	3 Full Threads	Every Hole

10. Cut two pieces of self-adhering flashing tape 4" taller than window side jamb nail fins. Apply flashing tape over the nail fins, covering the fasteners and onto the weather resistive barrier. Extend flashing tape 2" above and below head and sill nail fins.

11. Press and smooth flashing tape with a J-Roller.

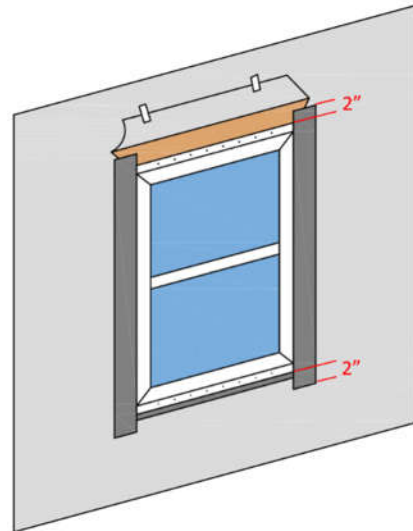

IMPORTANT

Make sure there are no wrinkles or voids in flashing during application. Make sure flashing covers the fasteners.

12. Cut one piece of self-adhering flashing to extend 1" past both side flashing tapes. Apply flashing tape over the head nail fin, covering the fasteners and onto the house sheeting.

13. Press and smooth flashing tape with a J-Roller.

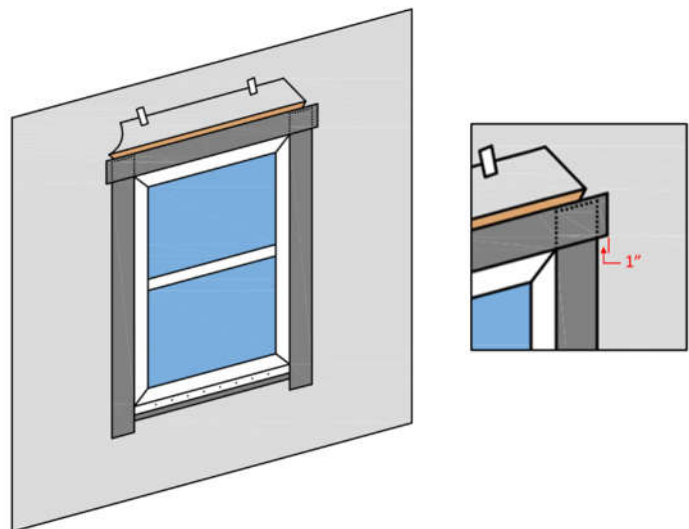

IMPORTANT

Side flashing cannot extend above top flashing. Doing so could result in product or property damage. Make sure there are no wrinkles or voids in flashing during application.

14. Unfold the top flap and tape 45degree cuts with house wrap tape.

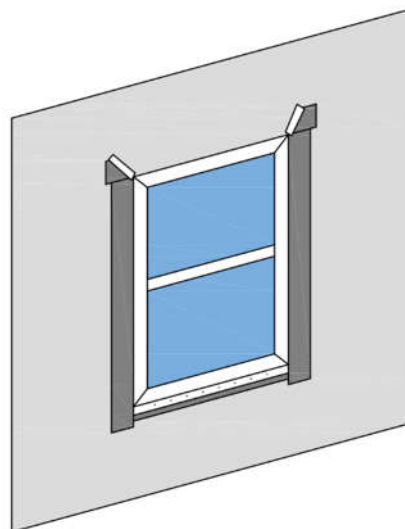

Interior Sealant Instructions

1. Apply sealant continuously to full perimeter of opening, filling interior 1/3 of cavity between window and rough opening using low expansion foam or backer rod and sealant.

IMPORTANT

When using low expansion foam be sure to apply foam between window frame and rough opening, NOT between jamb extensions and rough opening.

DO NOT overfill with low expanding foam or overpack with backer rod or insulation. Doing so could bow the window and result in poor operation and product performance. Any low expansion foam used should conform to AAMA 812-04, but any binding or damage of any type caused by the insulation will not be covered under warranty.

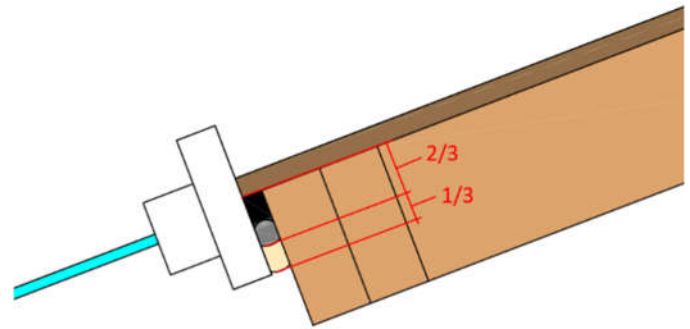

Operating and Cleaning Instructions

1. Turn the locking mechanism in the center of the sash counterclockwise to unlock the window. If the latch is tight and you have difficulty turning it, press down on the lower sash with one hand and turn the latch with the other. This loosens the grip between the two latch pieces, making it easier to slide.
2. Raise the lower sash at least 3 inches toward the top of the window. Squeeze the two tilt latches inward toward the window and hold. This will disengage the latches. Gently pull the top of the lower sash toward you until it is in a horizontal position. Once the sash is free from the frame, release the tilt latches.
3. For double hung units, slide the upper sash down at least 2 inches. Squeeze the two tilt latches and gently pull top of the sash towards you, just as you did the lower sash.
4. Using a mild soap or glass cleaning solution, adequately wet the glass surface. This will allow for more thorough cleaning and help prevent streaking when drying.
5. Use a clean, soft, lint-free cloth (a microfiber cloth is a good choice). If a squeegee is used, it should not contain metal components that could contact the glass surface.
6. To close the sashes, push the top of the sashes inward until the tilt latch buttons click into the main frame on both sides. Make sure tilt latches are fully engaged in the main frames, failure to do so could cause the sashes to fall inward causing damage. It could also cause damage to the sash interlocks.

Cleaning the Frame

Periodic cleaning of the main frame and sill area is recommended for ideal operation and maintenance. We recommend the use of mild soapy water to clean the frame. **DO NOT** use cleaning solutions, as they may react with the PVC, causing permanent damage. Acid solutions commonly used to wash masonry will damage glass, fasteners, and hardware. Follow cleaning solution manufacturer's recommendations carefully. Protect and/or cover windows during cleaning process to prevent acid contact. If solution does come in contact with unit, immediately wash with clean water.